



MZ

**Servomotor
for butterfly valves VF, VFH**

MZ

Servomotor

Contents

Description	2
Features	2
Functioning and application	3
Technical specifications	4
Operation	5
Manual mode	6
Automatic mode	7
DIP chart	9
Operating states	10
Ordering information	11
Standards and approvals	11

Description

Servomotor MZ is designed to operate VF and VFH butterfly valves, used with electronic positioning control of gas and air flow in combustion processes.

Features

DC motor with multi-stage spur gearbox.

High positioning precision performed by a 16-bit microcontroller.

Status LEDs and position indicator of the motor visible externally.

Provided with cams with double adjusting screw (adjustment tool included in the housing).

Two push-buttons for manual adjustment of the position.

Two push-buttons to save min./max. positions.

Analogue input and output signals for electronic positioning.

The same unit is suitable for 230-110-24V.

Adjustable opening time from 7s up to 60s.

Provided with connection for external programming terminal.

Its rugged and functional design allows a fast and easy installation, and it is practically free of maintenance.



WARNING

This control must be installed in compliance with the rules in force.

Functioning and application

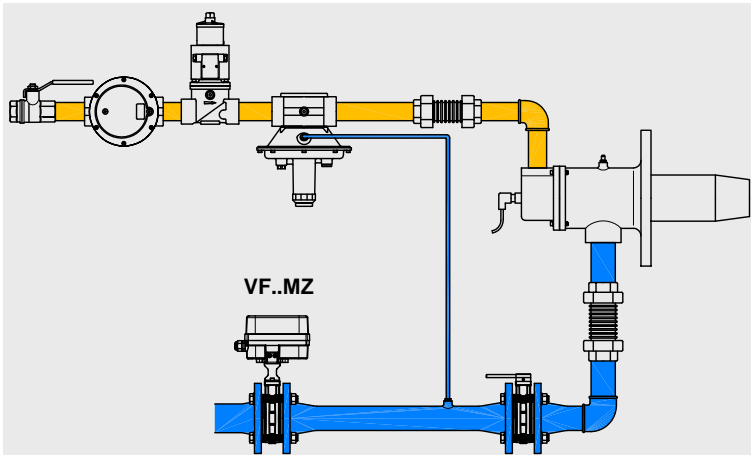

Fig. 1

- In case of combustion process being regulated by combustion air modulation, VF valves with servomotor can be used, coupled to another butterfly valve manually operated (available graduated scale and locking screw) to setup high-fire rate of the burner.

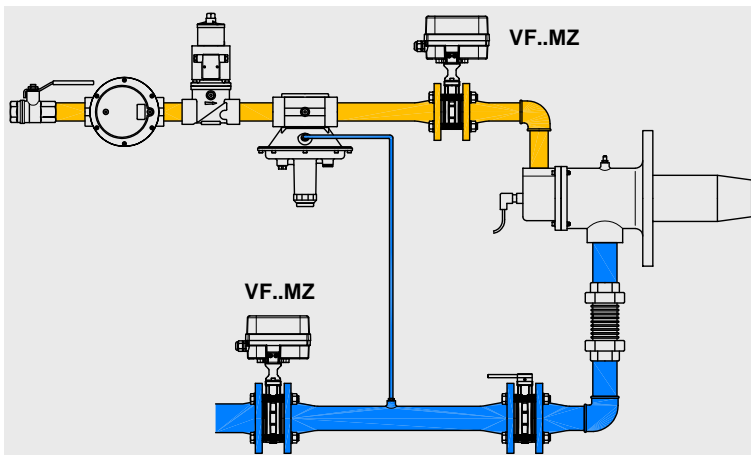

Fig. 2

- In case of combustion process with excess of air or gas, VF butterfly valve can be used, coupled to a Lambda sensor for ratio correction.

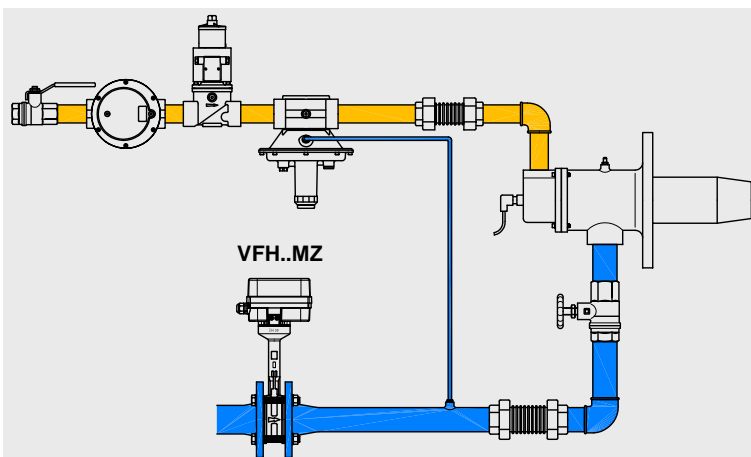

Fig. 3

- In case of combustion process with pre-heated air, VFH butterfly valve can be used with MZ servomotor.



WARNING

Location and mode of installation must be in compliance with local rules in force.

Technical specifications

Tab. 1

Servomotor type	Continuous adjustment of position by analogue signals			
Overall dimensions	See fig. 4			
Weight	2 Kg			
Rotation angle	0 / 90°			
Position repeatability	±0,25°			
Ambient temperature	-15°C / +60°C			
Voltage rating	230VAC 50/60Hz 110VAC 50/60Hz 24V AC/DC			
Voltage tolerance	-15% / +10%			
Power consumption	5 VA			
Protection class	Class I (EN 60335-1)			
Enclosure	IP65 (EN 60529)			
Cable gland	2x ISO 20 for cable O.D. 6 / 12 mm (EN 50262)			
Wires cross-section	2,5 mm ² max			
Torque (=holding torque)	5 Nm max			
Operating time (0 - 90°)	From 7s up to 60s (adjustable)			
Position switches electrical rating	Voltage 250VAC	Resist. Load 2A	Lamp. Load 0,3A	Induct. Load 0,3A
Analogue inputs	Signal type Overload max. Load impedance	0-10V 24Vdc 9,9KΩ	0-20mA 25mA 100Ω	4-20mA 25mA 100Ω
Analogue outputs	Signal type Load max.	0-10V 10mA	0-20mA 350Ω	4-20mA 350Ω

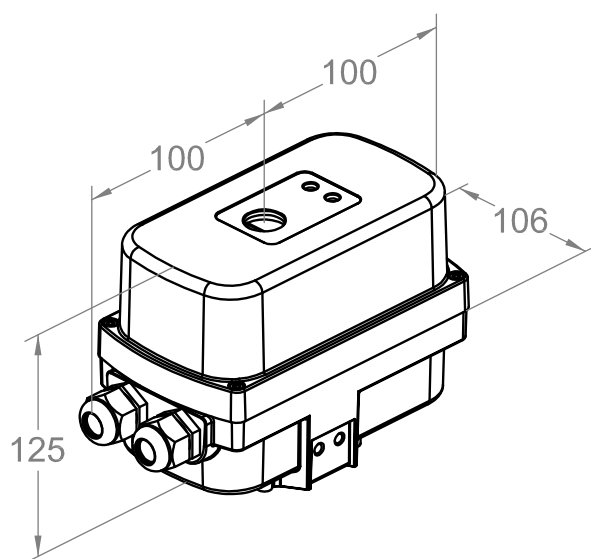
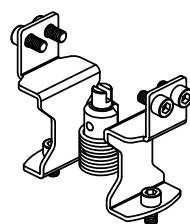
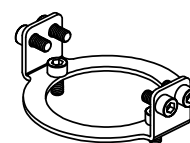

Fig.4

Adapter set for
VF butterfly valve
(Set M)Adapter set for
VFH butterfly valve
(Set MH)

Operation

This unit is designed for all applications that require high precision control of rotary movement between 0° and 90°. Inside the compact servo drive housing there is a DC electric motor, a gearbox and a control unit with a 16-bit microcontroller.

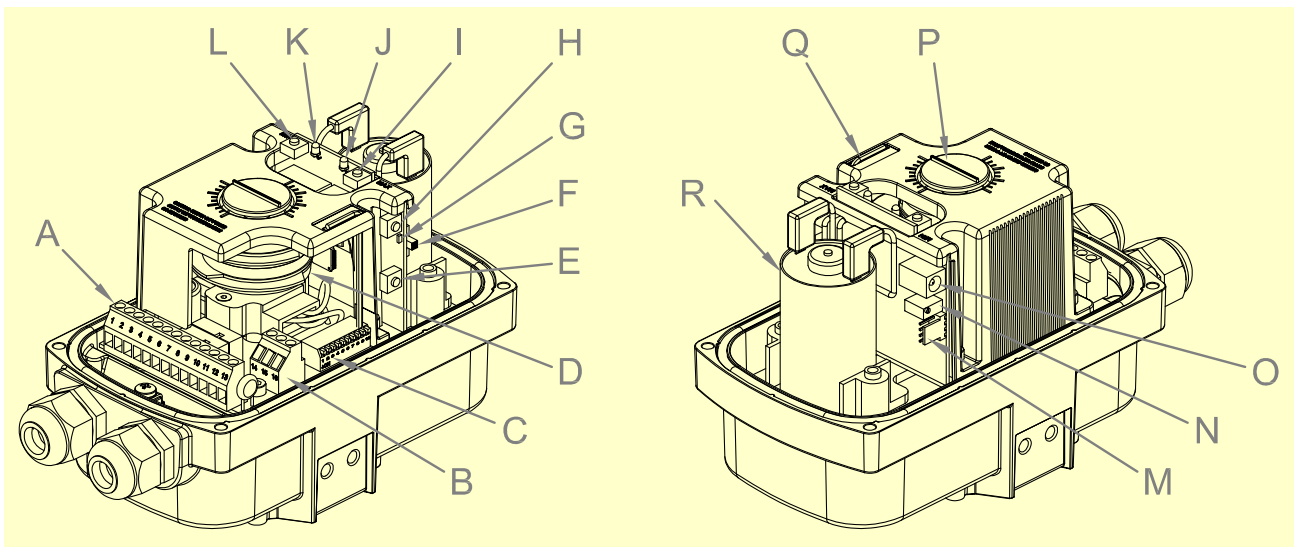

Fig.5

A	Main terminal block	J	Warning LED2 (red)
B	Analogue signals	K	Status LED3 (green)
C	DIP switch	L	MIN push button (B4)
D	Cams (C1, C2)	M	Board connector for Terminal (T1)
E	Closing push button (B1)	N	Hysteresis control
F	Automatic/ Manual switch (S1)	O	Direct motor driving
G	Manual operation LED1 (green)	P	Position indicator
H	Opening push button (B2)	Q	Cams adjustment tool
I	MAX push button (B3)	R	DC motor

The shaft rotation angle can be controlled via analogue signals and any position can be freely selected within the defined operating range. The hysteresis can be adjusted with a potentiometer in order to suppress interferences in the input signal. The current position can be monitored via output analogue signals.

MZ servomotor is provided with buttons for manual adjustment of the position and to save minimum/maximum limits. Some LEDs visible even externally, show the current status of the unit (e.g. manual operation, memorization, errors, etc.).

The most of settings can be made with an on board DIP switch (e.g. selection of analogue signals, sense of rotation, behaviour in the event of cable break, two-point operation). In the back side is also available a connection for the external programming terminal (T1), which can be used to set advanced features of the unit, to monitor some parameters (e.g. temperature, errors) or to upload new software releases.

On the back side is located a socket to connect a 5-12VDC power supply and perform direct motor driving, by-passing the control unit. It can be useful when either the control unit is failed or electrical power is missing and the valve must be operated anyway.

The servomotor is also provided with two auxiliary cams for the control of external devices.

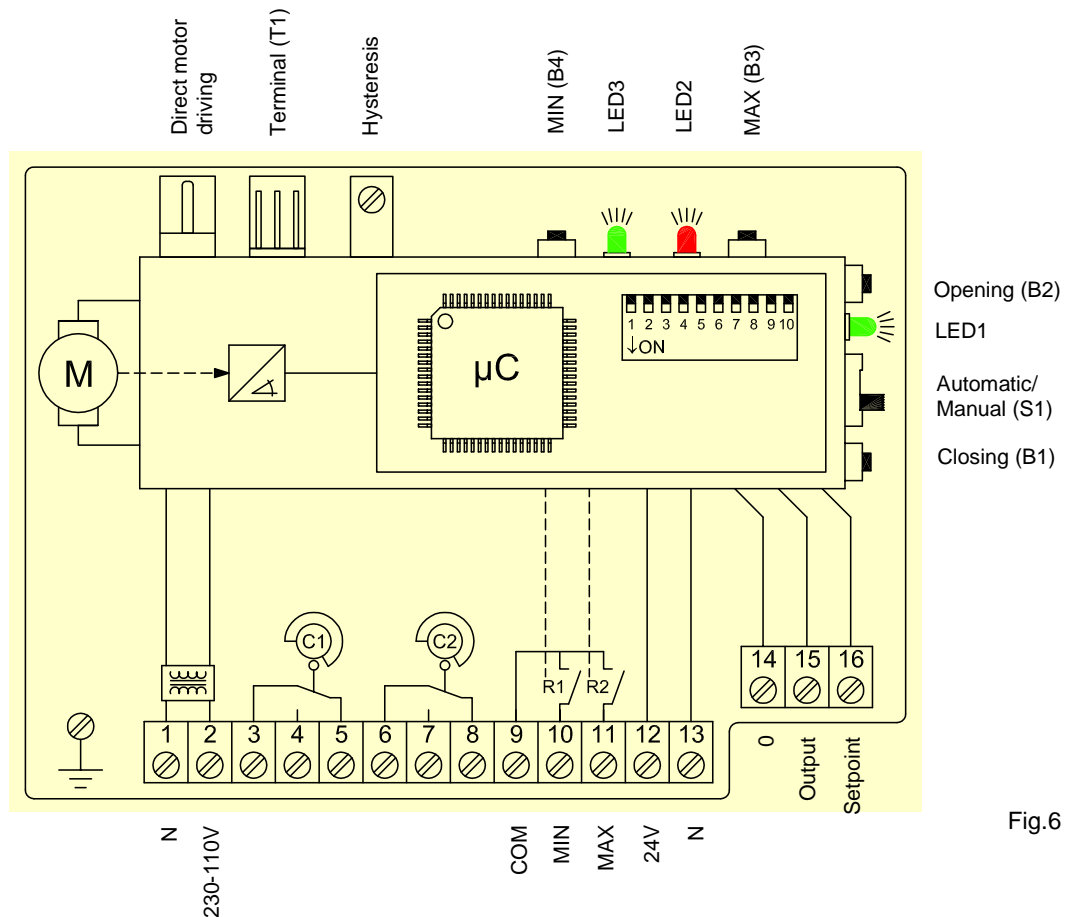

Fig.6

Manual mode

For a simplified commissioning, the actuator can be operated manually. The manual mode is useful to determine the operating positions for the process, such as the High/Low fire positions.

To enter in the manual mode shift the switch S1 upward (LED1 lights up). Now it's possible to move the valve toward the 90° position (counter clockwise rotation seen from the top), by pressing the button B2, and to move the valve toward the 0° position (clockwise rotation seen from the top), by pressing the button B1. The initial rotation speed is 0.25 RPM, this lets operator perform an accurate adjustment of position. If the button is pressed for more than 4 seconds the rotation speed shifts to 1 RPM.

Setting of the MIN and MAX positions

In manual mode it's possible to save current position as MIN (MAX) by pressing button B4 (B3) for more than 3 seconds (shorter pressing are not considered). When the position is saved, LED3 lights up permanently and the button may be released.

MAX position can not be lower than MIN saved position (and vice versa). In this case the position won't be saved and an alarm will go up (see "Alarms Chart") until a new proper position is saved.

Running time setting (continuous)

Factory standard setting for running time is 30s for 0-90°. However, requested running time is setup in the factory prior despatch according to customer's order information. In case of need, it can be modified on the field by the user by means of terminal T1 (optional) or in manual mode, according to following instructions.

Press both B3 and B4 buttons at the same time, keeping the buttons pressed for the *time* required (LED3 lights up). Running time must be included between 7 s and 60 s, otherwise its value will not be saved and an alarm will go up (see "Alarms Chart") until a new proper time is saved. The adjusted running time will become operative as the user switches from manual mode back to automatic mode.

Automatic mode

In the automatic mode the angular position corresponds to the input analogue signal supplied by a setpoint device. Factory setting allows full range of operation (0-90°) but, as above described, MIN and MAX position can be set within this range in manual mode.

An output analogue signal proportional to angular position is also provided.

Both input and output signals can be chosen between 0-10V, 0(4)-20mA setting the proper DIP switch configuration (see "DIP Chart").

Behaviour without input signal (4-20mA)

In the event of cable break or any other situation that a missing of input signal can happen, servomotor has to move in a defined mode. It's possible to set three different behaviour modes by the DIP switch: open position, closed position and stop (see "DIP Chart").

2-point control

The servomotor can work as 2-point device by means of an external relay (dry contact), setting the proper DIP switch configuration (see "DIP Chart").

Main power supply must be also provided.

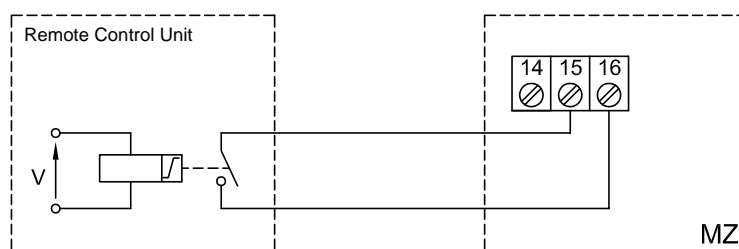

Fig.7

If a voltage V is applied to the relay terminals (contact closed), the actuator opens. If no voltage is applied to the relay terminals (contact open), the actuator closes.

3-point control

The servomotor can work as 3-point device by means of two external relays (dry contacts) coupled with two resistors, setting the proper DIP switch configuration (see "DIP Chart").

Main power supply must be also provided.

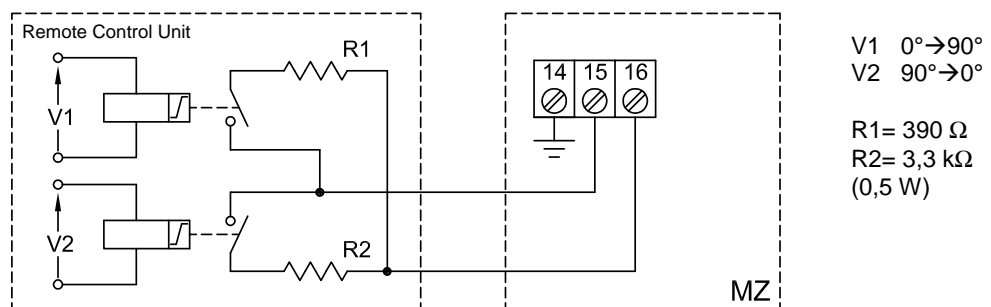

Fig. 8

The servomotor moves to MIN (0°) or to MAX (90°) when a voltage is applied to the related terminal (contact closed). If the voltage is switched off, the servomotor remains in the current position and the holding torque keeps it still without any additional brake.

Hysteresis and Filtration

The input analogue signal is processed internally with a resolution of 12 bit , corresponding to 0,025% of full scale (i.e. 0,004mA on a 4-20mA range). The hysteresis can be modified by means of a potentiometer from 10 up to 124 LSB. In order to avoid constant corrections of the positions due to signal fluctuations or noise, factory setting is 30 LSB.

The analogue input is sampled every 1 ms (*sampling rate*) and a mean value is generated over 0,1 s. This filtering can be prolonged by the terminal T1 (optional) up to 1 s, but this also prolongs the response time to a change at the analogue input.

DIP chart

■ = switch position

Input analogue signal

	1	2	3	4	5	6	7	8	9	10	0-10V
OFF		■	■								
ON											

	1	2	3	4	5	6	7	8	9	10	0-20mA
OFF											
ON	■	■	■								

	1	2	3	4	5	6	7	8	9	10	4-20mA
OFF	■										
ON		■	■								

Output analogue signal

	1	2	3	4	5	6	7	8	9	10	0-10V
OFF				■		■					
ON					■						

	1	2	3	4	5	6	7	8	9	10	4-20mA (0-20mA) programmable by means of T1
OFF					■						
ON				■		■					

Behaviour without input signal (4-20mA)

	1	2	3	4	5	6	7	8	9	10	Stop
OFF	■										
ON		■	■							■	

	1	2	3	4	5	6	7	8	9	10	Open position (MAX)
OFF	■									■	
ON		■	■						■		

	1	2	3	4	5	6	7	8	9	10	Closed position (MIN)
OFF	■								■	■	
ON		■	■								

Sense of rotation

	1	2	3	4	5	6	7	8	9	10	Right
OFF											
ON							■				

	1	2	3	4	5	6	7	8	9	10	Inverted
OFF							■				
ON											

Control type

	1	2	3	4	5	6	7	8	9	10	Analogue signals
OFF		■	■	■		■		■	■		
ON					■						

	1	2	3	4	5	6	7	8	9	10	3-point control activated
OFF		■	■	■		■					
ON					■		■	■	■		

	1	2	3	4	5	6	7	8	9	10	2-point control activated
OFF		■	■	■		■			■		
ON					■		■	■			

Operating state

Normal operation

Tab.2

Nr.	Status LED3 GREEN	Warning LED2 RED	State description
1	Fast flashing	OFF	Automatic mode
2	Slow flashing	OFF	Manual mode
3	Permanent light when position has been saved	OFF	Setting of the MIN and MAX positions (Manual mode)
4	Permanent light while buttons are being pressed	OFF	Running time setting (Manual mode)

Fast flashing: 4 times per second Slow flashing: 1 time per second

Alarms chart

Tab.3

Alarm Nr.	Status LED3 GREEN	Warning LED2 RED	Alarm type	Description	Cause
1	OFF	1 Flashing	Warning	Input signal is missing (4-20mA)	Cable break or disconnected, remote control defective
2	OFF	2 Flashings	Warning	Invalid position	Operator has attempted to save an invalid position (e.g. MIN>MAX)
3	OFF	3 Flashings	Warning	Invalid running time	Operator has attempted to save an invalid running time (out of 7-60 s range)
4	OFF	4 Flashings	Fault	Motor fault	Motor is defective
5	OFF	5 Flashings	Warning	Motor does not run	Motor is disconnected, potentiometer is disconnected
6	OFF	6 Flashings	Warning	Motor overload	Valve is blocked, direction of rotation is wrong
7	OFF	7 Flashings	Fault	Analogue signals defective	Test of analogue signals has detected a malfunctioning
8	OFF	8 Flashings	Warning	High temperature	Ambient temperature too high
9	OFF	Permanent light	Fault	Unit defective	Control unit defective, internal error

n-Flashing (2 per second) followed by a longer pause (2 seconds)

Product identification

Tab.4

	M	Z			
MZ	Model				
	Type				
	Z= advanced				
	Running time (1)				
<input type="radio"/>	7 s				
<input type="radio"/>	15 s				
<input checked="" type="radio"/>	30 s				
<input type="radio"/>	60 s				
<input type="radio"/>	7...60 s continuous (2)				
	Voltage				
<input checked="" type="radio"/>	A= 230VAC 50/60Hz				
<input checked="" type="radio"/>	B= 110VAC 50/60Hz				
<input checked="" type="radio"/>	C= 24VAC/DC				
	Inputs				
<input checked="" type="radio"/>	0-10 V				
<input checked="" type="radio"/>	0-20 mA				
<input checked="" type="radio"/>	4-20 mA				
	Outputs				
<input type="radio"/>	Potentiometer				
<input checked="" type="radio"/>	0-10 V				
<input type="radio"/>	0-20 mA				
<input checked="" type="radio"/>	4-20 mA				
For more information about butterfly valves see their technical sheets.					

● Standard ○ Optional ⊕ Adjustable ⊗ Not available

(1) to be specified if time is different from 30s and its setup has to be done in factory prior despatch

(2) customized time can be set up by user



Manufacturer reserves the right to update or make technical changes without prior notice.

Standards and approvals

The actuators meet current European approval requirements regarding electrical safety:

- Electromagnetic Compatibility (2004/108/CE)
- Low Voltage Directive (2006/95/CE)

Quality Management System is certified according to UNI EN ISO 9001 and the monitoring is carried out by the notified body:

Kiwa Gastec Italia Spa.
Via Treviso, 32/34
I- 31020 San Vendemiano (TV)

